

OWNER'S MANUAL

Model: F400 FOLDABLE / PORTABLE PATIENT LIFT

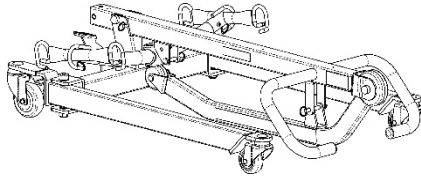

Folding Position #1 - Flat

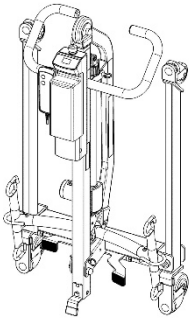

Folding Position #2 - Standing



SPAN

better science. better care.

Span-America Medical Systems, Inc.

Greenville, SC 29606

(800) 888-6752

BEFORE USE:



Ensure the product has been assembled according to the instructions in this manual. All operators should read and understand the instructions for safe and proper operation of the patient lift.

P16792 r1 CO#2604

Thank you for choosing Span

To better serve you, please record the following information for future use:

Supplier Name: _____
Supplier Telephone: _____
Product Serial Number: _____
Date of Purchase: _____

Date of Manufacture

FULL BODY PATIENT LIFT
F400
MAX LOAD: 400LB
MAX OF LIFT: 91LB(41KG)



The manufacture date can be found on the serial number. The YY on the serial number is the manufacture year, and the MM is the manufacture month.



This product has been tested by SGS, an accredited testing institute to comply with the requirements of:

ISO 10535, IEC 60601-1, ANSI/AAMI ES60601-1, CAN/CSA-C22.2 No.60601-1, IEC 60601-1-11, ANSI/AAMI HA60601-1-11, CAN/CSA-C22.2 No.60601-1-11, IEC 60601-1-2

Product Description

The Span-America F400 allows the patient to be lifted and transferred safely with minimal physical effort provided by the operator. This is due to it being a full electric lift. With the F400 patients can be lifted from floor to bed with ease. The F400 uses a six-point spreader bar. As an added feature this lift is able to be folded and stored away for people with limited space in the

home or in the trunk of your car for individuals who like to travel. With the addition of the optional battery pack you will never have to be worried about your lift not being charged and ready for use.



















Intended Use

The Span F400 is intended to be used with patients who are completely immobile or totally dependent on the patient lift for transfers. The F400 is intended for patients with limited space in the home or for customers who like to travel as it folds and fits in the trunk of your car. The F400 is intended to be used for transfers of the patient in and out of bed, their wheelchair, to and from the commode, or any other type of surface. The F400 is intended to be operated by one caregiver who will perform the lift and transfer. Transfers should always be done on a flat dry surface and are not intended to be used in high humidity environments for extended amounts of time.

DEFINITIONS & SYMBOLS

In this manual the user refers to the patient or resident and may be used interchangeably at different times. Caregiver refers to the operator or person who is assisting with the transfer.

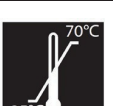
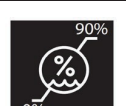
Symbols used in this manual and on the product and their meanings:

	Warning! Failure to heed this warning may result in damage to the product or serious injury to the operator and/or user.		Do Not Bleach. No bleach product may be used. The garment is not colorfast or structurally able to withstand any bleach.
	Important instructions follow. Read and understand the instructions in the manual before using the product.		Do Not Dry clean. Garment may not be commercially dry cleaned.
	Type BF applied part. Refer to the part of the medical device which come into physical contact with the patient in order for the device to carry out its intended		Do Not Iron. Item may not be smoothed or finished with an iron.
	Class II symbol. To identify equipment is designed that a connection to electrical earth (ground) is not required.		Tumble Dry, Normal, Low Heat. A machine dryer may be regularly used at a maximum of Low Heat setting.
	Note! Important information concerning the product and/or its correct and proper usage follows.		Do Not Dry. A machine dryer may not be used.
	Advise the operator to consult the accompanying documents before use.		Machine Wash, Hot. Initial water temperature should not exceed 82°C or 180°F.
	Right side up		Do Not Wash
	Fragile, handle with care		Keep dry
	Carton storage temperature limit of -25°C to 70°C		Carton storage humidity limit of 0% to 90%
	European Conformity mark, The product conforms to European Medical Directive 93/42/EEC and meets applicable health, safety and environmental requirements.		Handle with care

Safety Instructions

A Span-America patient lift will provide years of service if it is properly maintained as any electric and/or mechanical equipment requires. Please pay careful attention to the following important information regarding the care, maintenance, and operation of the patient lift. Carefully read these instructions before assembling the lift, or attempting to lift a user with the device.

- Before attempting to lift any patient, please practice operating the lift and explain the lift procedures to the patient.
- Please provide special assistance under the caretakers' discretion. (i.e. patients who are comatose, spastic, agitated, or otherwise severely handicapped.)
- The patient lift should be used solely for transferring a user/patient from one utility (beds, chairs, toilets, etc.) to another. The patient lift should not be used for transporting or moving any patient from one location to another location.
- During lifting or lowering, whenever possible, always keep the base of the lift in the widest position.
- The base of the lift should be closed before moving the lift.
- Do not roll casters over any object while the user/patient is in the sling.
- Do not lock casters during lifting.
- While being lifted in a sling, always keep the user/patient centered over the base and facing the caregiver operating the lifter.
- Never leave the user/patient unattended during lifting.

Service personnel may contact Span-America for any information, instructions, or certain parts for servicing purpose.

⚠️ WARNING!

- **NO** modification of this equipment is allowed. It is unsafe to modify the equipment from its original state. This product is deemed safe to use with only the original parts as delivered. Unauthorized use of any modified equipment may result in serious injury or death.
- **DO NOT** replace any components of the lift without consulting with Span-America and must follow proper instruction from Span when replacing any components.
- **DO NOT** service any parts of the lift while in use with a patient.
- It is **NOT** safe to load the equipment more than the indicated maximum safe working load.
- **IF** any accessories with lower load capacity than the equipment itself is used, **DO NOT** load the equipment more than the lowest maximum safe working load.
- **REMOVE** the battery pack if the lift will not be used for some time, to prevent battery leakage. **PERIODICALLY** check the battery pack and the charger
- This equipment **DOES NOT** consist of any materials or ingredients to which patients are exposed, that may cause bodily harm or injury.
- Prolonged exposure or physical contact with any part of the equipment **WILL NOT** cause skin irritation, allergic reaction, etc.
- Using accessories, detachable parts, or materials not described in the instruction manual **MAY RESULT IN SERIOUS INJURIES.**
- Keep the equipment away from children and pets when in use. **IT MAY CAUSE SERIOUS INJURY OR DEATH.**
- Keep the equipment away from any pests or pest infested area. Diseases transferred from pests to the equipment **MAY CAUSE SERIOUS ILLNESS** to patients upon contact.
- If the lift is exposed to the sun for long periods of time, be **CAUTIOUS** as the surface of the lift may be hot.
- There is no risk if the lift is exposed to reasonably foreseeable environmental conditions
- **CAUTION!** The controller contains parts and assemblies that could be susceptible to **damage by electrostatic discharge (ESD)**. To reduce the likelihood of this, one should be grounded prior to using the controller.
- **DO NOT** use the lift on an inclined surface that is greater than 5°.

FEATURES & OVERVIEW

i Prior to assembly, unpack and inspect all parts from the shipping carton. Contact you dealer immediately if any parts are damaged or missing.

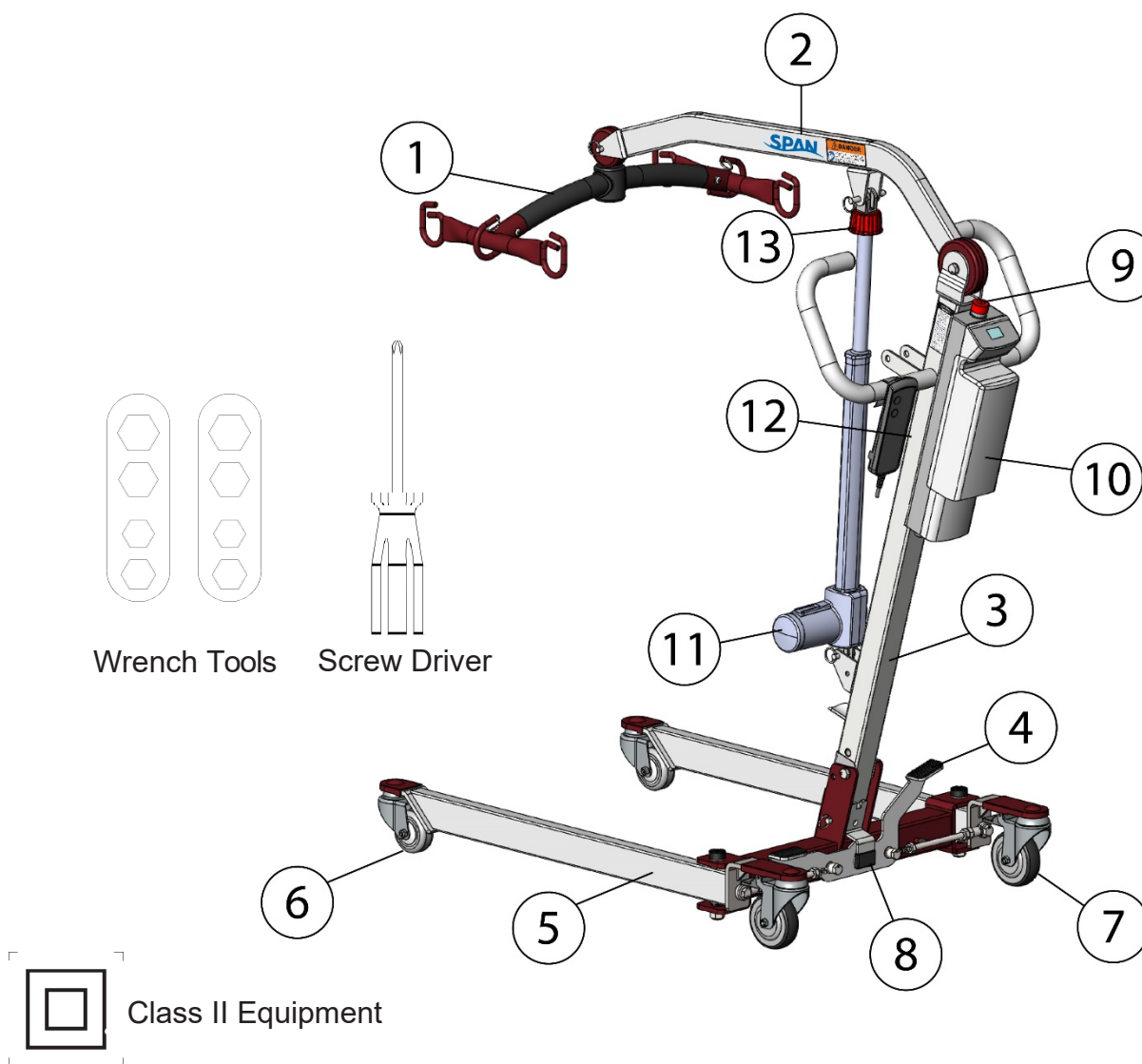

1	Spreader Bar	Combined Weight (1-5) 69.8lb (31.7 kg)	6	Front Caster	11	Actuator	7.6 lb (3.5 kg)
2	Boom		7	Rear Caster	12	Hand Control	0.7 lb (0.3 kg)
3	Mast		8	Standing Bracket	13	Emergency Lowering	
4	Leg Opening Pedal		9	Emergency Stop Button		Charger	0.6 lb (0.3 kg)
5	**Base		10	Control Unit			11 lb (5 kg)

** Heaviest detachable part

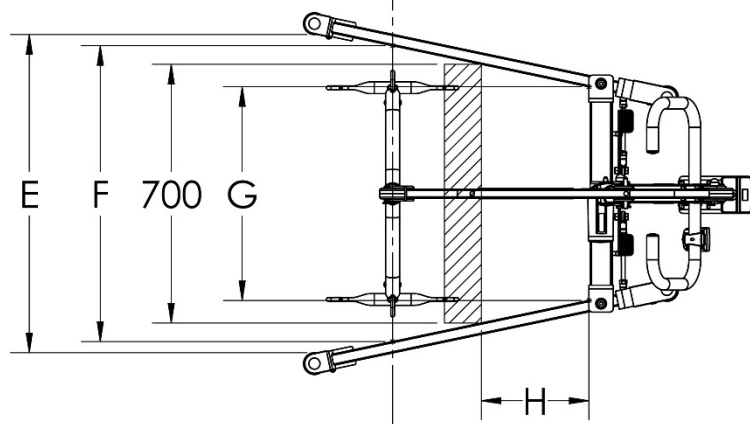
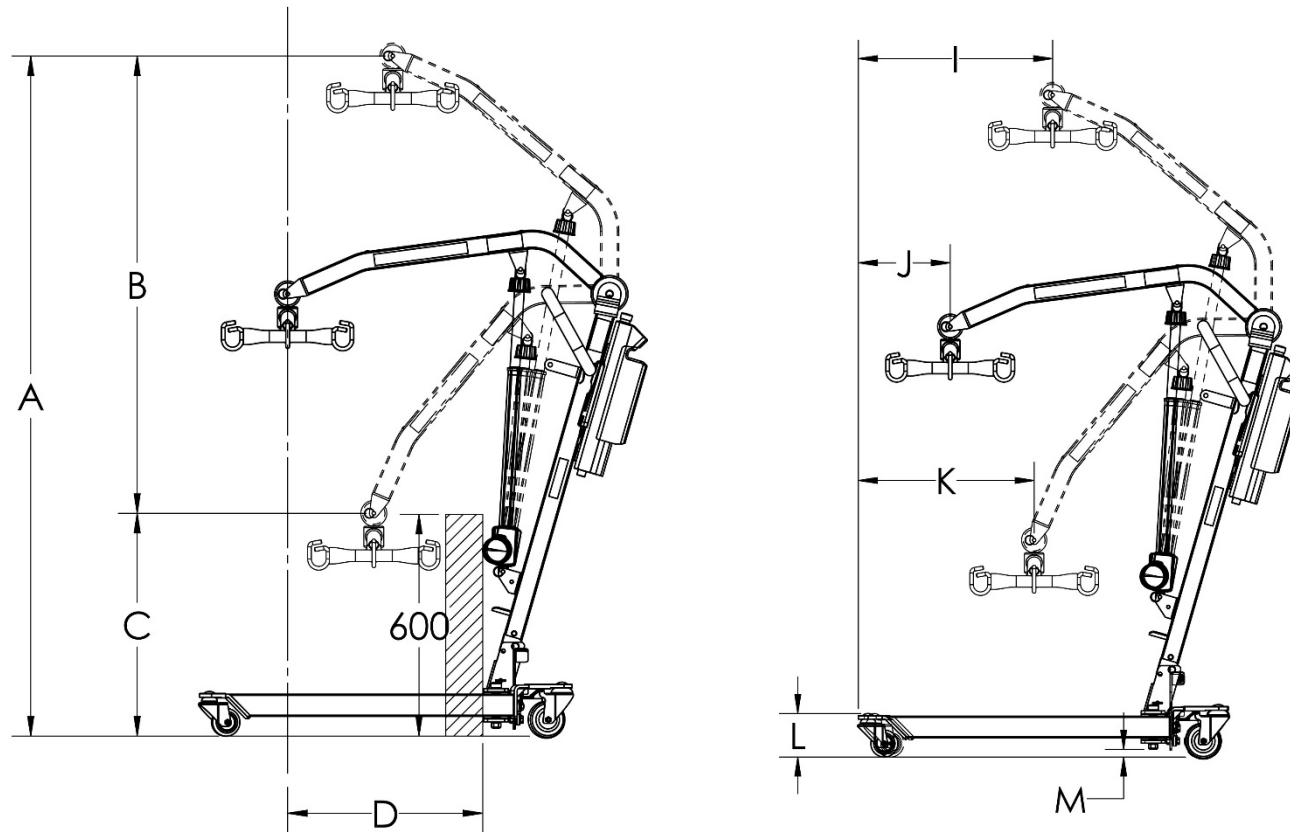
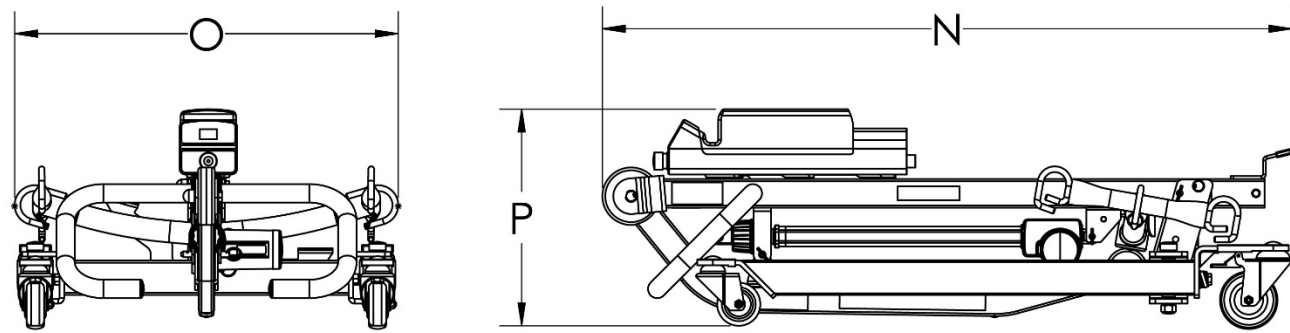

	mm	(in)
A	1841.2	(72.5)
B	1237.5	(48.7)
C	603.7	(23.8)
D	526.7	(20.7)
E	812.8	(32.0)
F	771.4	(30.4)
G	576.6	(22.7)
H	336.4	(13.2)
I	544.1	(21.4)
J	258.4	(10.2)
K	491.0	(19.3)
L	121.0	(4.8)
M	20.3	(0.8)
N	1198.8	(47.2)
O	657.5	(25.9)
P	377.1	(14.8)

SPECIFICATIONS & OPTIONS

Specifications of Control Unit	
Input Voltage	220-240VAC 50Hz / 110-120VAC 60Hz
Output Voltage	24 VDC
Battery Pack	24 VDC 5AH
Lift Control	Handset and Panel
Protection Class	IP54 (Protection against dust and splash of water)
Sound Level Under Full Load	16db
Sound Level Under No Load	11db
Lift Cycles Per Charge	25 full cycles under full load
Overload Warning	by LCD
Battery Status	by LCD
Duty Cycle	10% Duty cycle (Max 2 minute ON, 18 minute OFF)

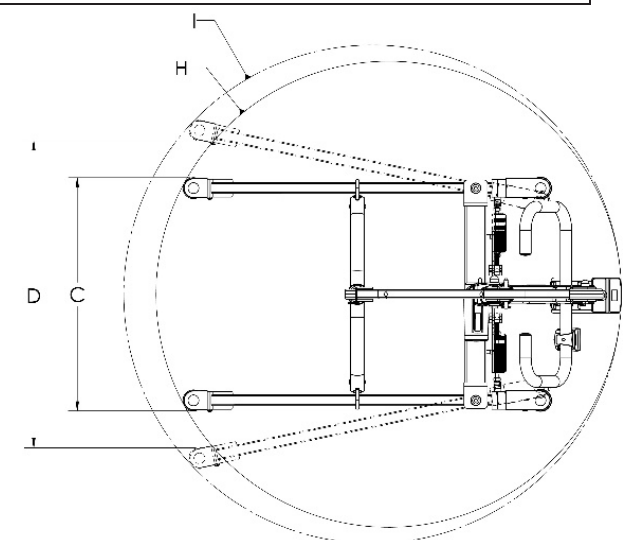
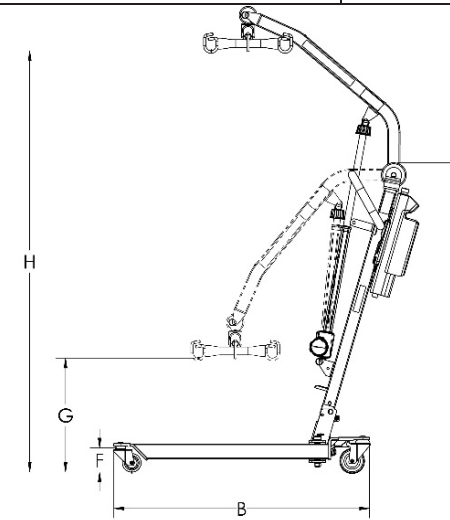

Dimensions & Specifications		
A	Safe Working Load	400 lb 182 kg
B	Base Length	41.7" 1059.2mm
C	Base External Width – Closed	25.7" 652.8mm
D	Base Internal Width – Opened	32.7" 830.6mm
E	Mast Height	48.3" 1226.8mm
F	Front Caster Height	4.7" 119.4mm
G	Lifting Height – Lowest	18.3" 464.8mm
H	Lifting Height – Highest	67" 1701.8mm
I	Turning Diameter	55" 1384.9mm
	Unloaded Lift Weight	91 lb 42 kg

Standard Features

- 6-Point Spreader Bar
- 4" Rear Caster with Brake
- 3" Front Caster
- Power Control Unit

Optional Features

- Charging Cradle
- Digital Scale (P11634)
- Additional Battery Pack

* Span-America is committed to continuous improvements of our products therefore the specification, dimensions, and features listed above are for guidance only and are subject to change without prior notice.

Step 1: Remove folded lift from box

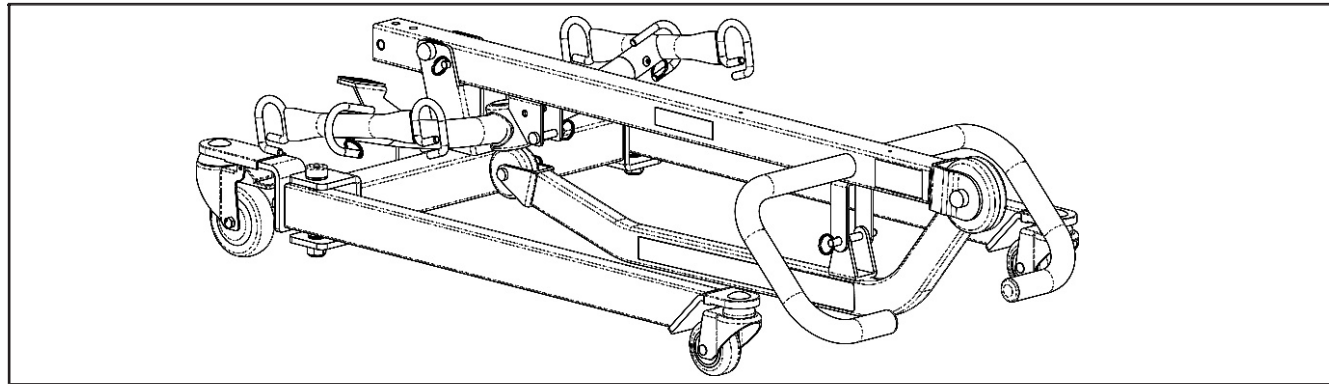

Step 2: Secure the stand to the mast. Make sure the tab on the standing bracket sits in the top hole on the mast, and insert the screw to the lower hole as follows. Use the EZ-Tools to tighten the screws. Note: The standing bracket may come pre-installed at the factory

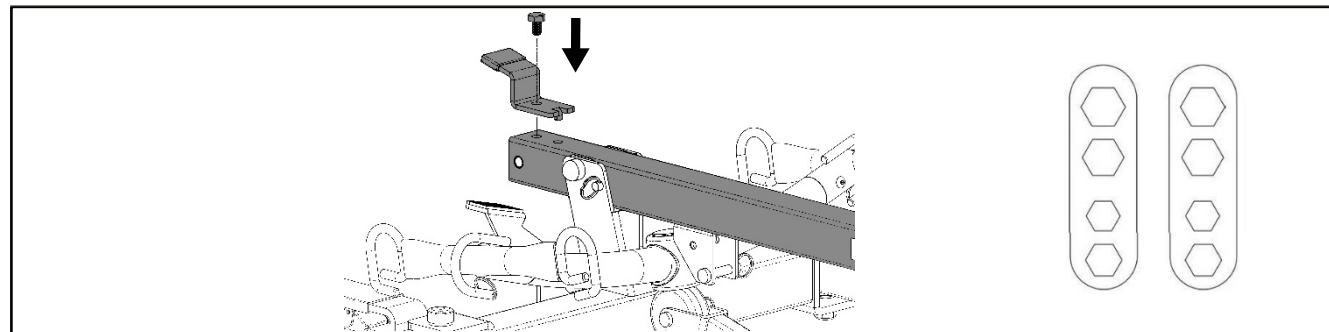

Step 3: Remove the quick release pin that is securing the mast

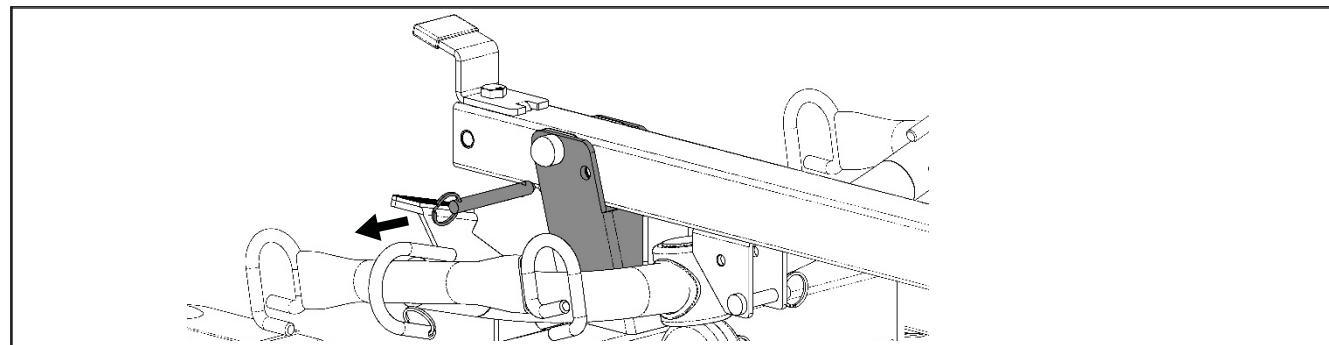

Step 4: Lift the mast upright. Lock the rear casters first, then lift the mast upright by grabbing onto the handle bars

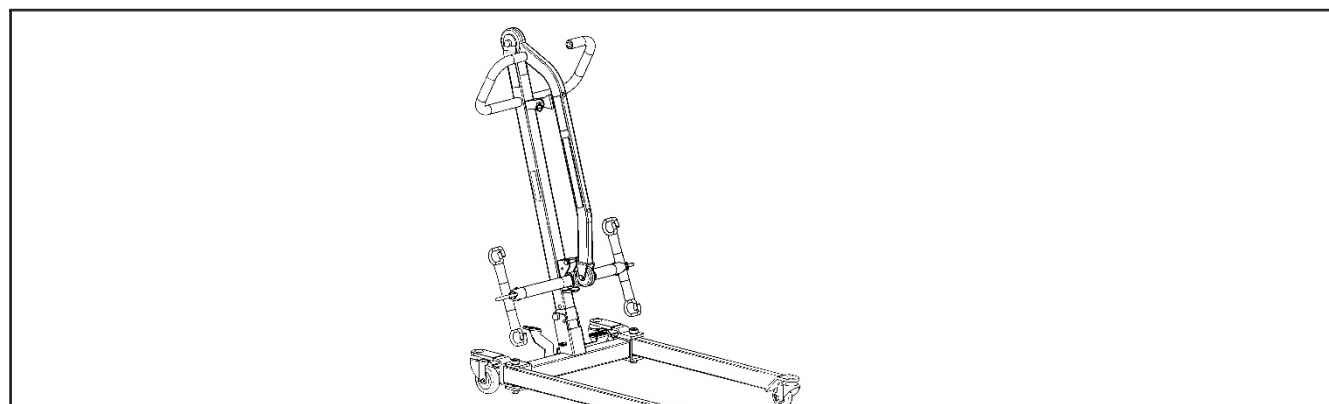

Step 5: Insert the pin to secure the mast

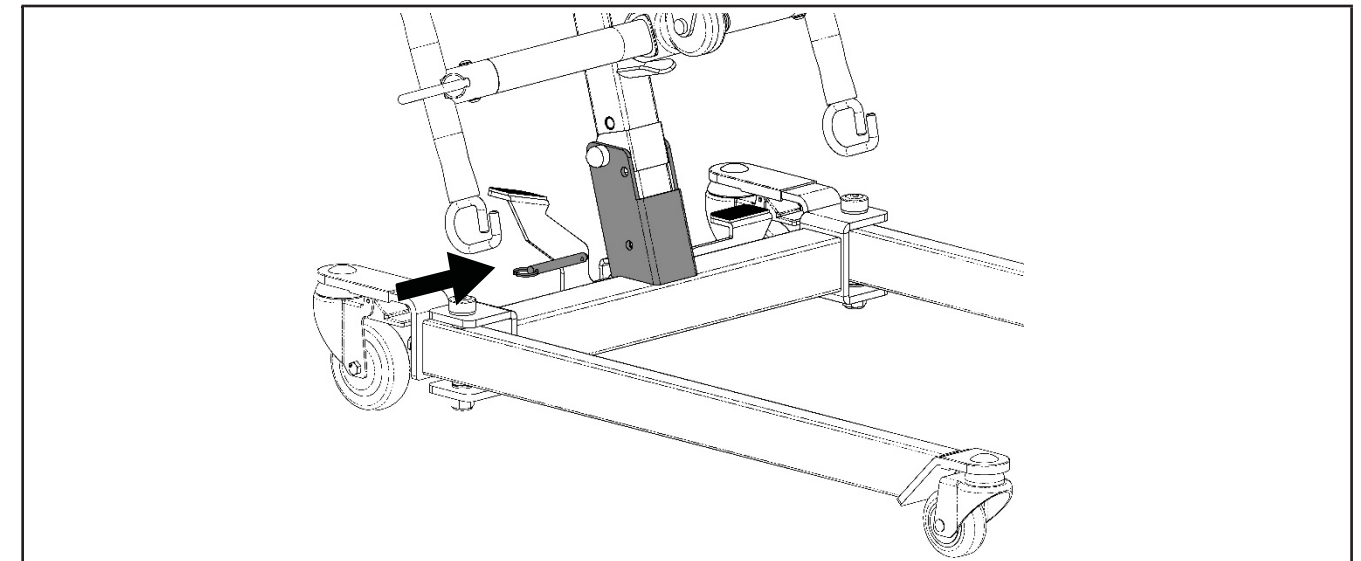

Step 6: Remove the pin that is securing the boom

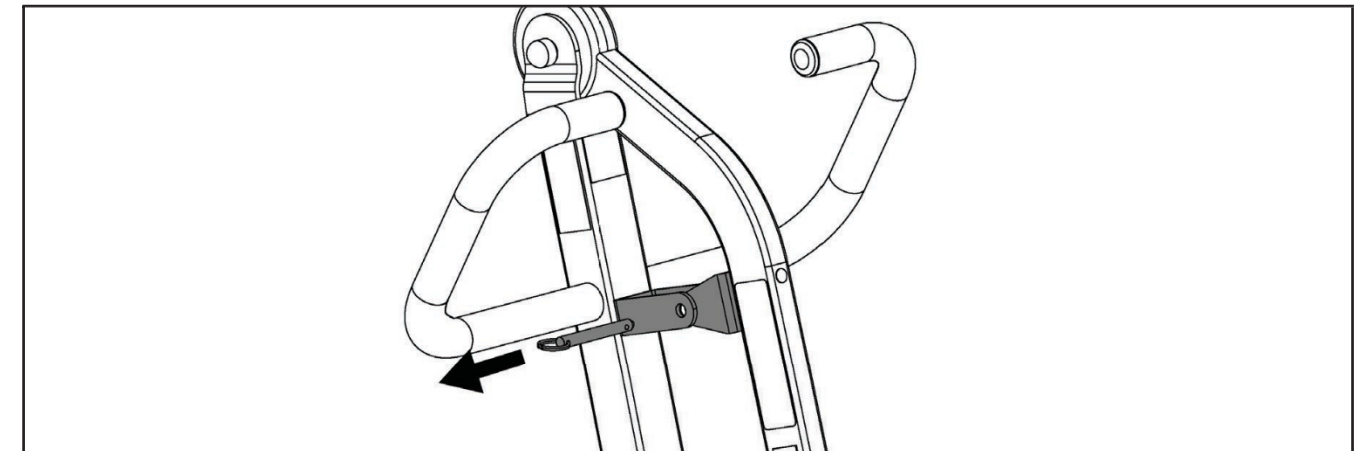

Step 7: Remove lower actuator pin

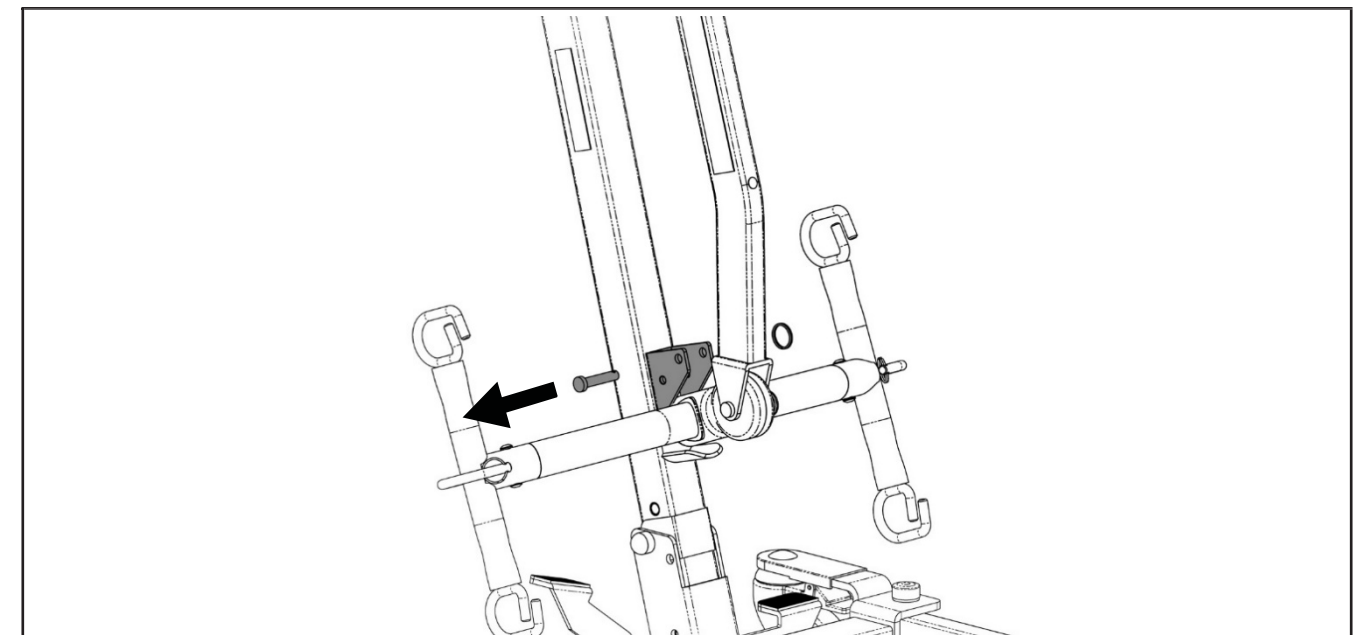

Step 8: Move the boom out of the way, and install the lower end of the actuator as follows

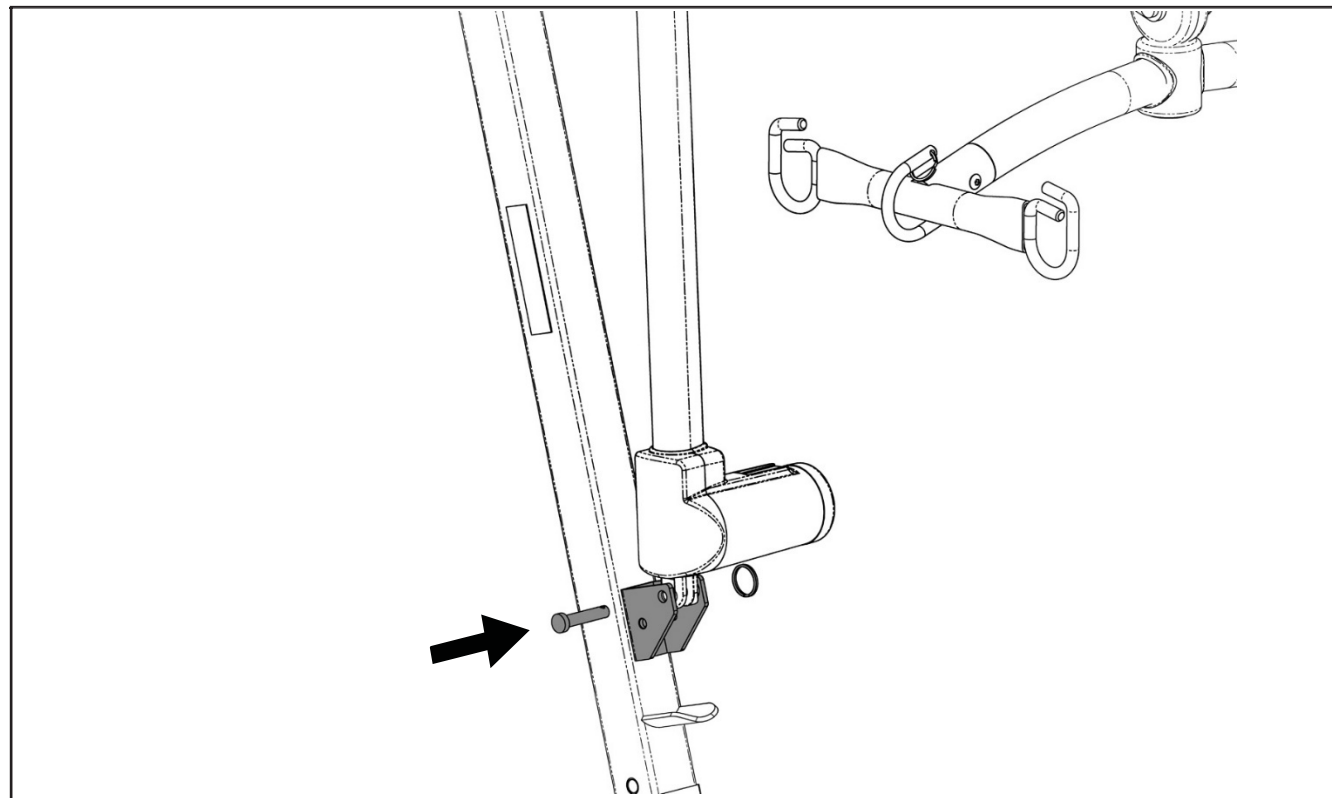

Step 9: Install the upper end of actuator and reinsert the quick release pin to secure it.

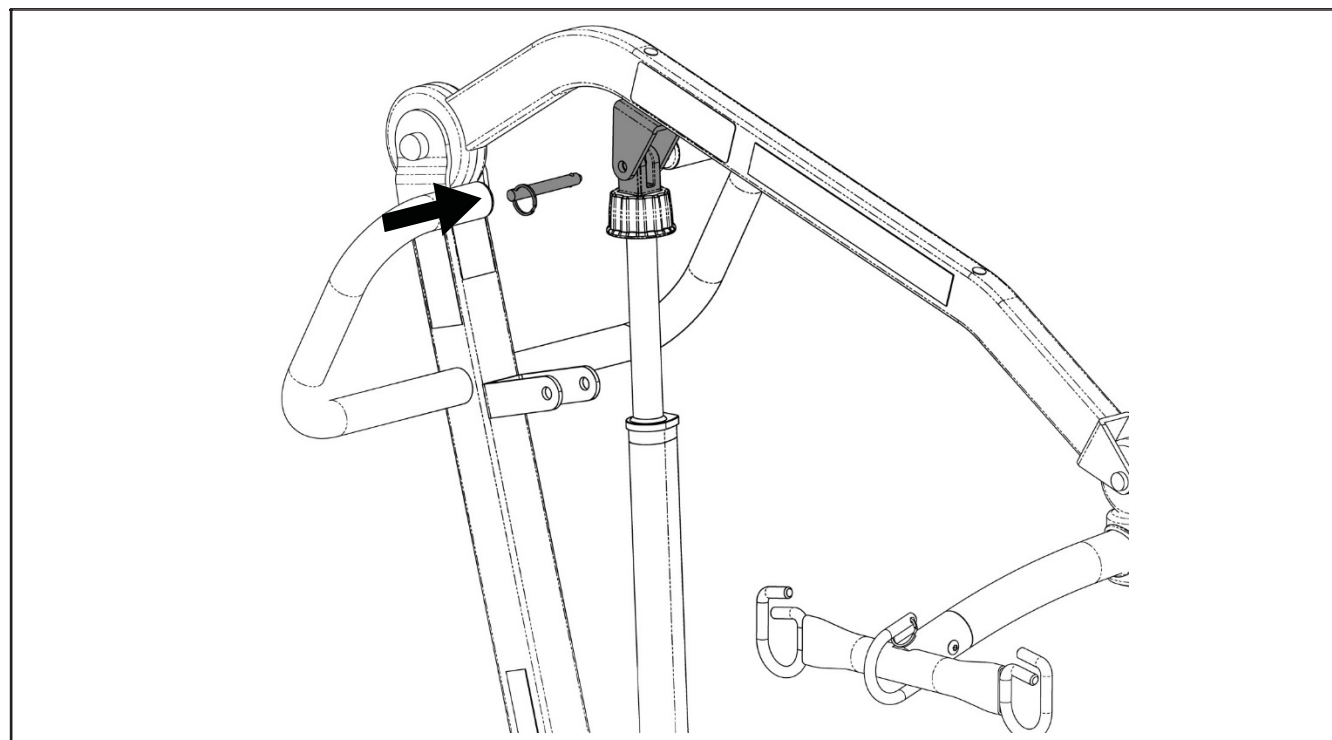

Step 10: Installing the Control box on the Lift

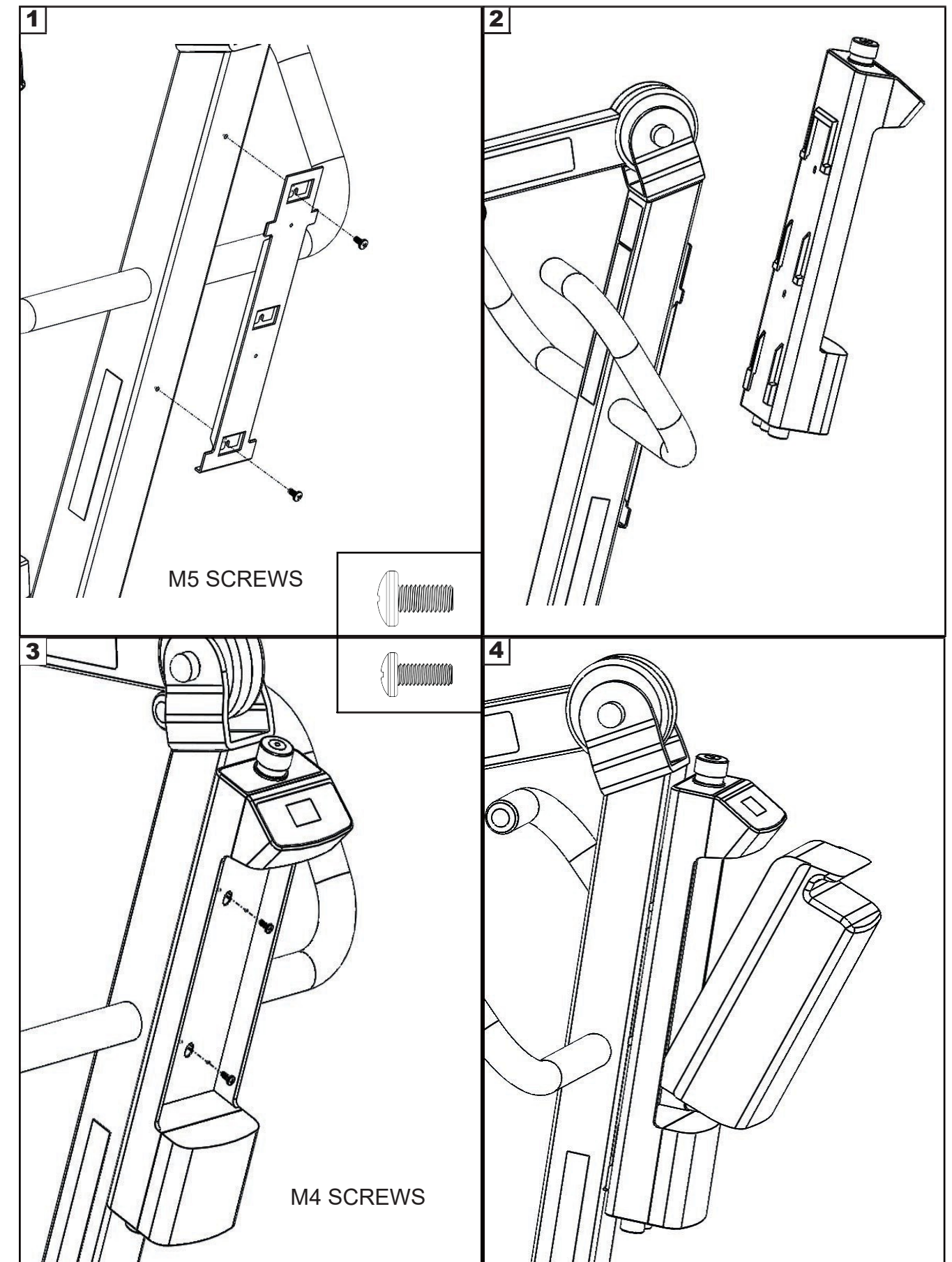

Folding the F400 for Storage or Transport

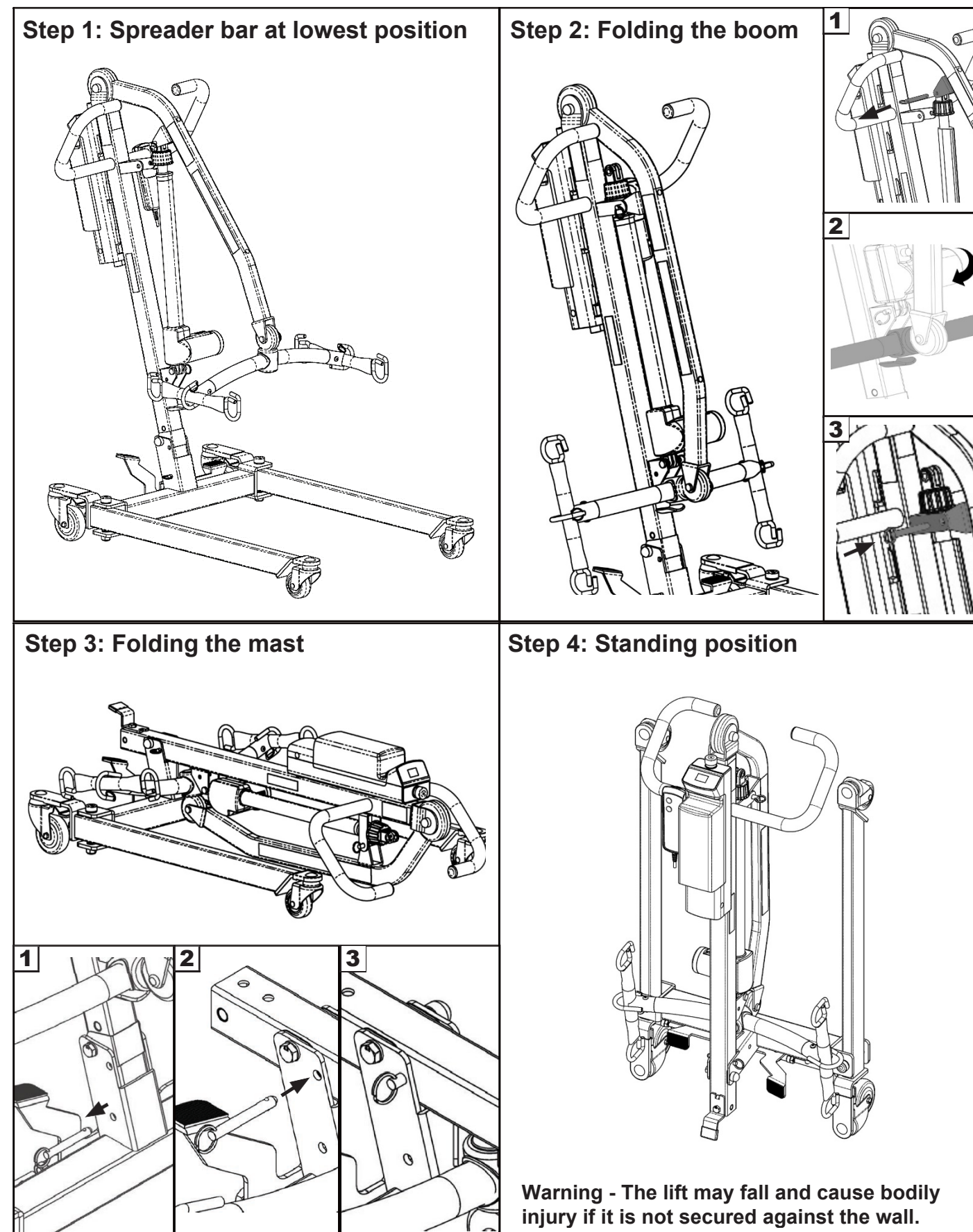

Operating Instructions



Double check all assemblies for tightness and read operating instructions carefully prior to use.

For optimum performance the lift should be transported and stored in following condition range:

- -25°C to +5°C (-13°F to 41°F), and
- +5°C to +35°C (41°F to 95°F) at a non-condensing relative humidity 0% to 90%
- +35°C to +70°C at a water vapor pressure up to 5 kPa

For optimum performance the lift should be operated in following condition range:

- at a temperature range of +5°C to +40°C (+41°F to +104°F)
- at a non-condensing relative humidity range of 15 % to 90 %, but not requiring a water vapor partial pressure greater than 5 kPa
- 70 kPa to 106 kPa atmospheric pressure

The lift will not have any potential electromagnetic or other interference with other devices.

PREPARATION BEFORE LIFTING

- Twist the RED EMERGENCY STOP BUTTON clockwise.
- Verify the Lifting and Lowering Functions by pressing either the UP or DOWN button on the hand control once.
- Position the base of the lift around or under the object.
- Widen the base and disengage the caster brakes.

 Do not attempt to transfer a patient without prior approval of the person's nurse. Also, do not transfer without having studied the instructions and performed several practices in operating the product. Together (with the patient's doctor, nurse, or medical attendant) select a sling that is both practical and comfortable. The sling selected should be one that serves the needs of the patient, while providing the patient with optimal safety. Never interfere with the lift, unless instructed by the attendant. Have a doctor, nurse, or medical attendant present during the first few times the lift is used to transfer a new user.

Power Control Unit Overview

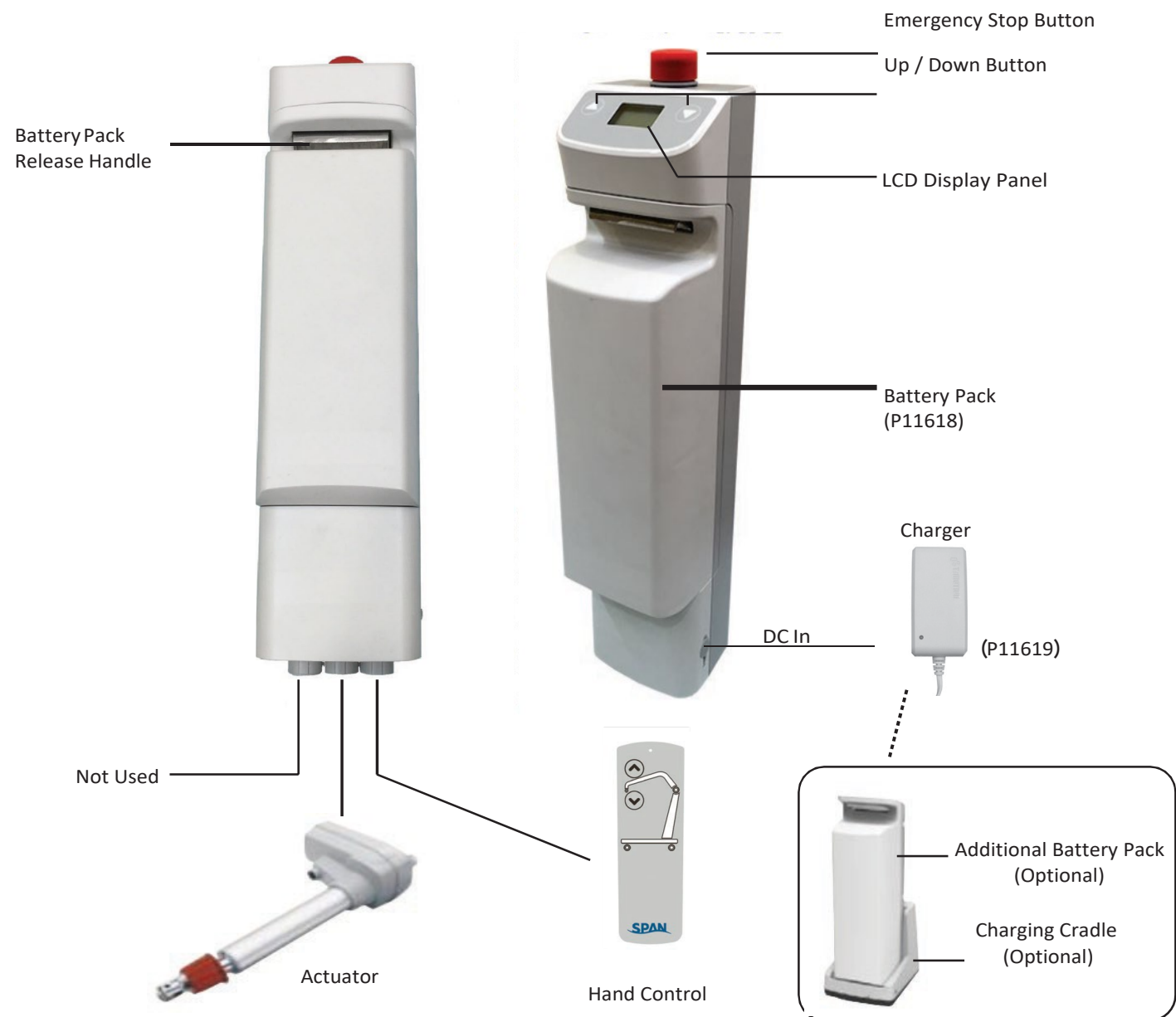

1. Connect Actuator as shown above.
2. Connect Hand Control as shown above.

WARNING!

- Contains a long charger cord that may cause strangulation if used improperly
- Keep long charger cord out of walkway where it poses a tripping hazard
- Have the charger port on the controller facing away from the wall for easy disconnection

Release



Pressed in

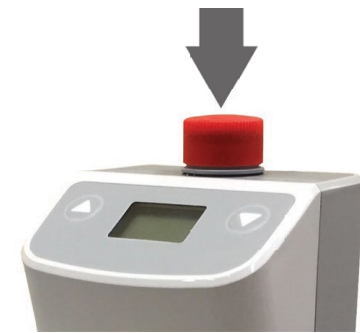

LCD Display Panel Signs

When the emergency stop button is released, the LCD Display Panel will show one of the four signs below.

- The sign will display for 5 seconds.
- Then the lift will go into standby mode and the sign disappears.
- The lift is ready for use.

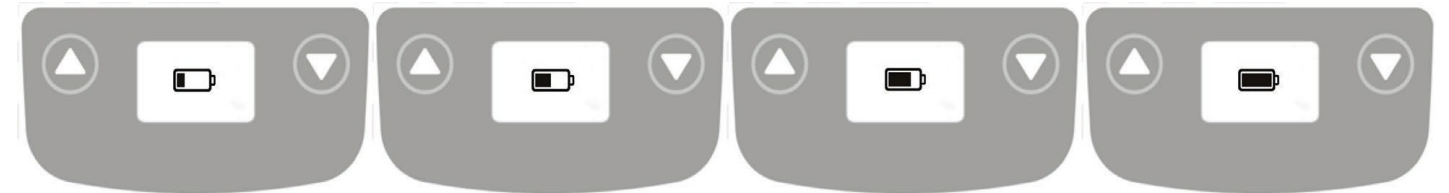

Charging: DC Charger or Charging Cradle

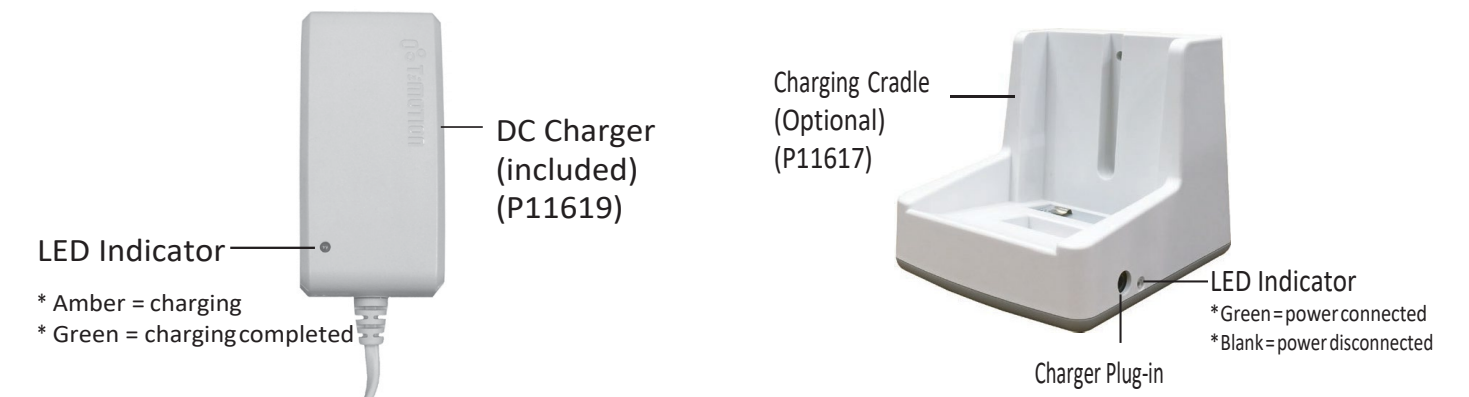

LCD Display Panel Signs - Charging

During charging, the LCD Display Panel will show one of the four signs below.

- The DC Charger must be connected.
- The emergency stop button must be released.
- The battery will not be charged if the emergency button is pressed in.

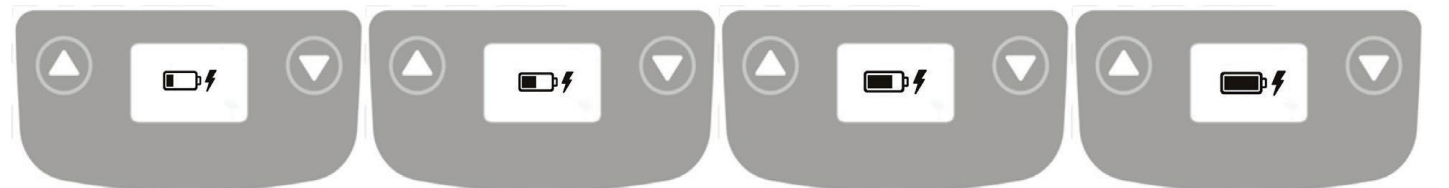

Operating Lift: Using Hand Control

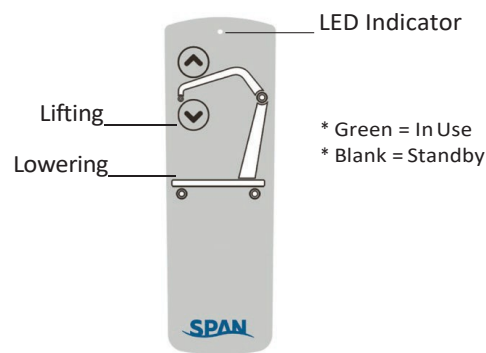

Button	Press Button	Release Button

Operating Lift: Using LCD Display Panel

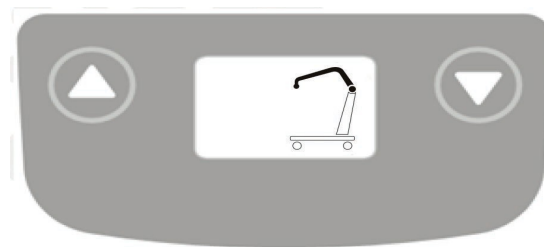

Button	Press Button	Release Button

Warning! - Battery Low and Charging is Needed

If the battery needs to be charged, the LCD

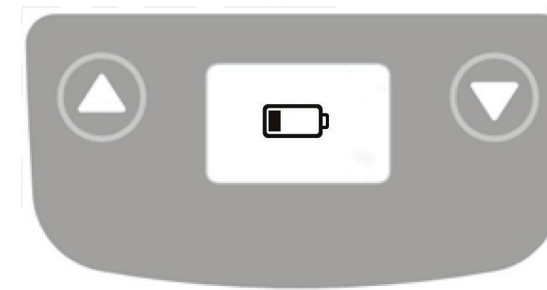

Display Panel will show a blinking low battery sign shown on the left either when the emergency stop button is released or when a button on the LCD Display Panel is pressed.

- Lift is still functioning.
- Buzzer will beep every 2 seconds.
- Battery needs to be charged immediately after use.

Warning! - Overloaded



During lifting if the lift is overloaded, the LCD Display Panel will show the sign on the left and lifting will be deactivated immediately.

- The buzzer will beep 3 times.
- Lowering the lift by pressing the DOWN button is still allowed.
- The emergency stop button must be pressed in and then release the button before further lifting.

Warning! - Charge Battery Immediately

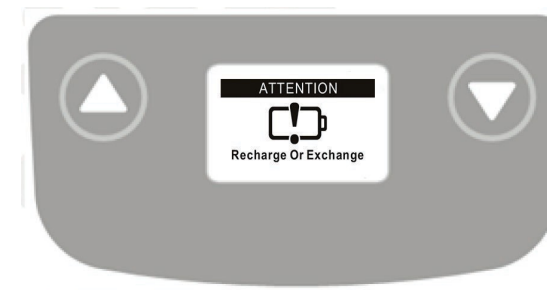

If the battery is critically low, the LCD Display Panel will show the sign on the left either when the emergency stop button is released or when a button on the LCD Display Panel is pressed.

- Lift operation is deactivated.
- Battery needs to be charged immediately before further use.

Available slings compatible with Patient Lift

Sling Type	Material	Sizes
Universal with head support (Span-America)	Mesh with padding	M921500-XS M921500-S M921500-M M921500-L M921500-XL M921500-XXL
Universal without head support (Span-America)	Mesh with padding	M921501-XS M921501-S M921501-M M921501-L M921501-XL M921501-XXL
Hygienic Sling (Span-America)	Polyester	M921502-XS M921502-S M921502-M M921502-L M921502-XL M921502-XXL
Disposable universal with head support (Span-America)	Nonwoven, Disposable	M921505-XS M921505-S M921505-M M921505-L M921505-XL M921505-XXL
Sani	Polyester	S, M, L, XXL
Invacare® Replacement	Polyester	M, L, XL
	Mesh	M, L, XXL
Invacare® Replacement with Head Support	Mesh	M, L, XL, XXL
Hoyer® Replacement	Polyester	M, L, XL
Hoyer® Replacement with Head Support	Polyester	M, L, XL
Liko®/Guldmann® Replacement	Polyester with PU Coating	M, L, XL
Liko®/Guldmann® Replacement with Head Support	Polyester with PU Coating	M, L, XL
Liko®/Guldmann® Disposable Replacement	Nonwoven, Disposable	M, L, XL
Liko®/Guldmann® Disposable Replacement with Head Support	Nonwoven, Disposable	M, L, XL
Pediatric with Head Support	Mesh	Standard
	Polyester	



If the patient is pregnant or has skin conditions, consult with a doctor before use.



ALWAYS check that the sling weight capacity is suitable for the patient



All slings are type BF applied parts

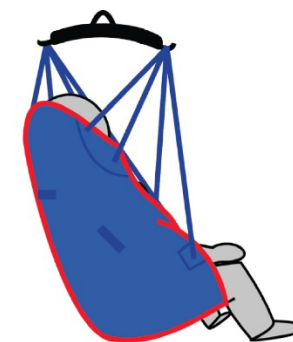

Sling Hook-Up Guide

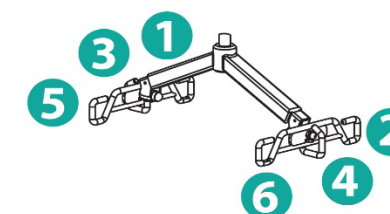

6 Point S-Bar (Standard)

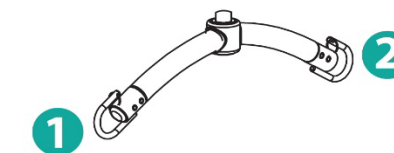

2 Point S-Bar (Optional)
item# P17038

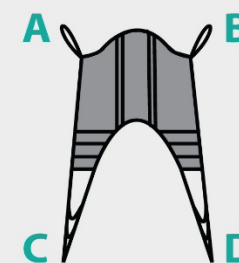

4 Strap Sling

Hook up A → Point 1
Hook up B → Point 2
Insert D through C
Hook up D → Point 5
Hook up C → Point 6

Hook up A → Point 1
Hook up B → Point 2
Insert D through C
Hook up D → Point 1
Hook up C → Point 2

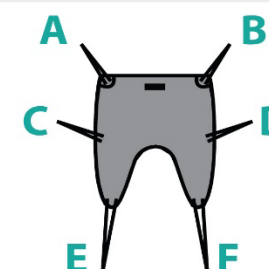

6 Strap Sling

Hook up A → Point 1
Hook up B → Point 2
Hook up C → Point 3
Hook up D → Point 4
Insert F through E
Hook up F → Point 5
Hook up E → Point 6

Hook up A, C → Point 1
Hook up B, D → Point 2
Insert F through E
Hook up F → Point 1
Hook up E → Point 2

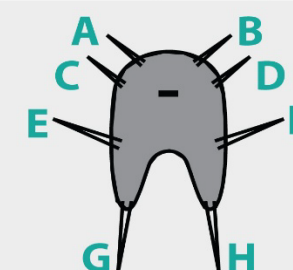

8 Strap Sling

Hook up A & C → Point 1
Hook up B & D → Point 2
Hook up E → Point 3
Hook up F → Point 4
Insert H through G
Hook up H → Point 5
Hook up G → Point 6

Hook up A, C, E → Point 1
Hook up B, D, F → Point 2
Insert H through G
Hook up H → Point 1
Hook up G → Point 2



BEFORE LIFTING THE PATIENT, PULL ON EACH SLING LOOPS TO ENSURE THE LOOP IS HOOKED ONTO THE SPREADER BAR PROPERLY.

For further product information and support, please contact your dealer or visit our website at www.spanamerica.com

Transfer From Bed to Wheelchair

1. User/patient should be in the center of the bed.
2. Position user onto his/her side by rolling user towards you.
3. Roll the sling in half. The handle on the back section sling should face outward when the sling is fitted.
4. Position the sling under the user/patient so the commode aperture aligns with the base of the spine and top of the sling close to the neck.
5. Roll user onto the opposite side and position him/her on the flat section of the sling. This will allow you to unroll the remainder of the sling from the other side of the user.
6. Once the sling has been positioned in the center of the user/patient, feed the leg sections under the thighs and draw them up between the thighs.
7. Raise the head of the bed if this function is available.
8. Move the lift slowly towards the user and position the spreader bar over the user's/patient's chest. Attach clips of the sling to the hooks on Spreader Bar as shown in the Sling Hook-Up Guide.
9. Lift the user above the bed by using the hand control.
10. Pull lift away from bed. Position user over the wheelchair or chair then lower the patient onto the surface.
11. Reverse the above procedures when returning the user/patient to bed.

Transfer From Wheelchair to Bed

1. Help the user lean forward slightly, then slide the sling down between the chair and the user's back.
2. Position the commode aperture where the buttocks meets the seat.
3. Position the sling equally around both sides of the body.
4. Draw the leg sections to the front along the length of the user's thigh.
5. Check the sling's central positioning by comparing the lengths of the leg sections when they are drawn forward.
6. Reposition the sling if the leg sections are not equal in length.
7. Feed the leg sections under the thighs.
8. From between the legs, gently pull the leg section up the inner thigh. Feed as much material as possible under and between the thighs. Ensure the leg sections are positioned midway under the thighs to provide good support and greater comfort.
9. Move the lift slowly towards the user and position the spreader bar over the user's chest. Attach clips of the sling to the hooks on Spreader Bar as shown in the Sling Hook-Up Guide.
10. Lift patient above the wheelchair by using the hand control.
11. Pull lift away from wheelchair. Position patient over bed and lower patient onto bed.
12. Reverse the above procedures when returning the user/patient to a wheelchair.

Maintenance & Inspection



- The operator of the lift shall inspect the Span lift before each use. Check all bolts for tightness. Make sure the base can be easily widened, and that all lift parts are in place. Make sure that casters can be turned freely, and that caster brakes can be engaged. Make certain all necessary items (i.e. slings, and wheelchairs, etc.) are ready for use.
- At least once a month, the lift should be thoroughly inspected by a person qualified to recognize any signs of wear and tear, and looseness of bolts or parts. Replace any worn parts immediately.
- To lubricate, put silicone lubricating grease on the following points when the Span lift is placed into service and every month thereafter: Top of Mast, Spreader Hinge, and Caster Axles.
- With proper use and care, the expected lifetime of the lift is 10 years or 20,000 cycles.
- The expected lifetime of the electrical components are 3 years

	First Received	Monthly	Every 3 Months
Boom & Spreader Bar			
Check connections between boom and spreader bar for improper connection.	●	●	
Check connections between boom and mast for improper connection, looseness or wear.	●	●	
Check the boom for bending and deflection.		●	
Mast			
Check the mast for bending or deflection.	●	●	
Base & Foot Pedal			
Check bolts and nuts for looseness.	●	●	
Check casters and axle bolts for tightness.	●	●	
Check rubber parts on the casters for deflection.	●		●
Apply grease to caster ball bearings if needed.			●
Check welding joints for rust and crack.		●	●
Actuator & Control Box			
Make sure the control box is firmly affixed to the mast.	●	●	
Make sure the actuator is secured to the boom and mast with pins and key rings.	●	●	
Make sure actuator plug into control box is not loose.	●	●	
Sling & Sling Hardware			
Check sling for wear.	●	●	
Check sling hardware every time before use.	●	●	
Lift Cleaning	As Needed.	As Needed.	As Needed.

Cleaning and Disinfecting

Cleaning of the lift

- Use pH-neutral detergents only.
- Remove the battery from the controller
- Clean lift surfaces, control box and hand control with a damp cloth using pH-neutral detergent.
- Remove debris and hair from the casters and make sure the casters can spin and swivel freely.



- Solvents or strong liquids or abrasive cleaning products will damage the surfaces of the lift.

Cleaning of the sling

- Check with sling label for washing condition.
- As for minor cleaning between patient uses, we recommend wipes with water-soluble soap or isopropyl alcohol.
- For slings with rigid supports, remove the plastic inserts before washing. (Look for an opening near the plastic inserts for removal)
- Machine wash warm or cold.
- Do not wash with other colors.
- Air dry or very low dryer heat.



- DO NOT USE BLEACH.
- DO NOT clean or wash disposable slings.
- REPLACE a sling when it shows signs of deterioration.

Deterioration of sling

- Contact Span-America for “Guideline for Identifying Deteriorated Slings” if needed.

Disinfecting of the lift and sling

- Inspect slings prior to each use for contamination from previous use.
- Use isopropyl alcohol for any disinfection purpose.



- Wash a reusable sling for serious contamination
- Replace a disposable sling for any contamination
- Reusing a contaminated sling can cause serious bacterial infection

Troubleshooting Guide

The following list of encountered problems and solutions will assist you in determining what may be causing your patient lift not to function as designed. If you have a problem occurring which is not listed below please contact your dealer or technical support for help. Do not attempt to repair or replace components or parts on your lift as this may void your warranty or cause further problems that may result in patient injury. Stop using your lift immediately if it is not functioning correctly or any warning beeps are heard.

I need to re-charge my batteries often or they fail to hold a charge when I charge them.

- Replace the batteries or battery pack as they are at the end of their life cycle
- Batteries should be changed every 18-24 months depending on usage

The actuator will either go up or down but not both

- Replace your hand control as it is at the end of its life cycle
- Your control box may be malfunctioning

There is a grinding sound inside the actuator when lifting

- Replace your actuator as the internal gears are stripped

The actuator stops and starts while lifting or lowering

- Replace the batteries or battery pack as they are at the end of their life cycle

My lift will not operate even though it shows the batteries are charged

- Unplug the AC power cord from the control box as the lift will not work when the control box/charger is connected to AC Power.
- Check to make sure the hand control is properly inserted all the way into the control box port.
- Check to make sure the actuator plug is properly connected and inserted all the way into the control box
- Your hand control needs to be replaced as it is at the end of its life cycle

If there is a problem you could not solve, please contact your dealer for assistance.

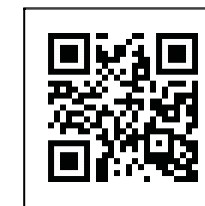

Emergency Lowering Mechanism

Contact your dealer immediately if standard troubleshooting techniques do not correct the failure. Do not attempt to lift until all failure and safety issues have been resolved.

In case of lift failure, please follow the procedures below to safely lower the user.

The Emergency Lowering Device is located at the top of the actuator shaft. It is intended for use if the actuator or electronics fail to operate while the patient is suspended in midair.

The device consists of a plastic collar ring that should be first pulled down and turned clock-wise continually until the patient has been lowered.

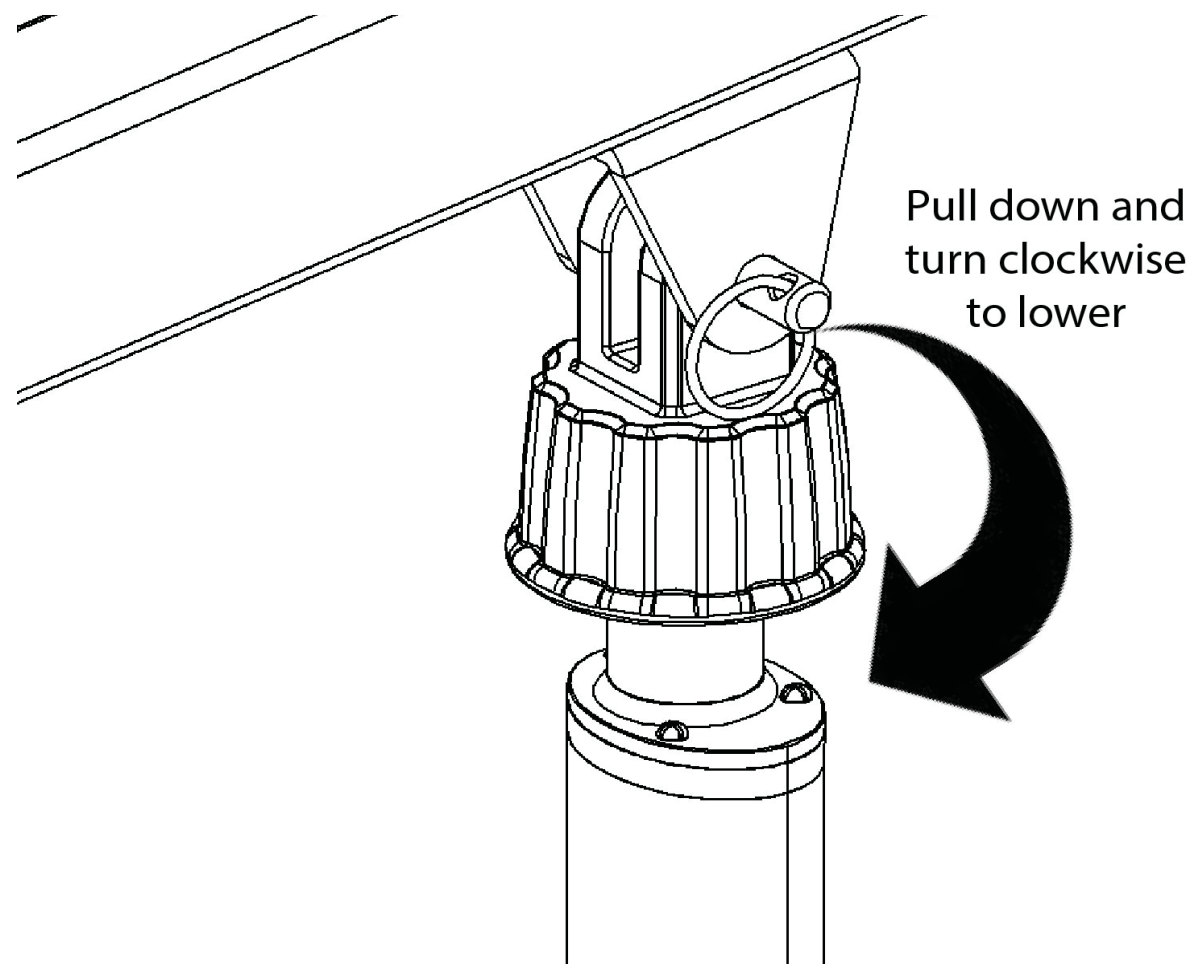

NOTE:
THE EMERGENCY LOWERING DEVICE IS INTENDED FOR USE DURING LIFT FAILURE. THIS DEVICE WILL ALLOW LOWERING OF PATIENTS ONLY. PLEASE CONTACT YOUR DEALER IMMEDIATELY IN CASE OF FAILURE.

WARRANTY POLICY

Span-America ("Span") offers a limited warranty on all patient lifts, slings and accessories to be free of defects in workmanship and product performance. This warranty extends only to the original purchaser and is non-transferrable. All warranty claims must be submitted by the authorized dealer or distributor who originally sold the product with proper proof of sale and serial number where applicable. Prior Return Authorization (RA) from Span is required for all warranty replacements. Span reserves the right to repair or replace only defective parts or accessories in lieu of a complete new patient lift. The repaired or replacement part shall be warranted for a period equal to the remainder of the warranty period of the defective part.

Span does not provide advance replacements for warranty claims. For situations where an end user requires a replacement in advance and before a warranty item can be returned, dealer or distributor must purchase the replacement at full cost. All freight charges for the replacement are the sole responsibility of the dealer or distributor. When end user returns warranty item and item proves to be defective, Span will issue full credit for the replacement less freight charges.

Product returned without RA number clearly marked on the package or product returned later than 30 days after authorization will be refused and returned at sender's expense. Final disposition of warranty claims will be determined at the sole discretion of Span. Warranty claims will be denied for any of the following: product abuse or misuse, accidental or malicious damage, improper installation, product used with parts, components or accessories with quality or specifications incompatible with product, adulterated product, user neglect, failure to maintain and service product as specified in the owner's manual or care tag, serial number removed or defaced, or normal wear and tear.

Span warrants the following products and components beginning from the purchase invoice date for the specified time period:

WARRANTY PERIOD	PRODUCT OR COMPONENT
Three (3) Years	Patient lift frame or spreader bar
Two (2) Years	Actuator, control box, pendant, charger, weigh scale, or casters excluding normal tread wear
One (1) Year	Battery pack
Six (6) Months	Reusable fabric slings

Single Patient Specific slings are designed for limited use with one patient and may not be laundered. Span will replace any disposable sling found to have a manufacturing defect. Normal wear and tear will not be covered under warranty.

This warranty expressly excludes wearable components including but not limited to foam parts and caster tread. Furthermore, this warranty is void and null for product that has not been purchased or paid for in full.

RETURN GOODS POLICY

Patient lifts may not be returned unless the wrong lift is shipped in error by Span or the lift is heavily damaged or defective out of the box. For all other items, purchaser may request a RA for purchased goods within thirty (30) days of purchase invoice date. All returns must be received by Span no later than thirty (30) days after authorization or the RA will be voided. Return package must be clearly marked with the RA number or the package may be refused and returned at sender's expense. Patient lifts are subject to a minimum restocking fee of 25% or more. Please note that patient lifts being returned must be in the original carton with all parts, components and packing materials included. Failure to comply with this requirement will incur higher restocking fees or a rejection of the return. Slings, parts and accessories may only be returned if they have not been used. There are no exceptions to this provision.

All freight charges are the sole responsibility of purchaser when any of the following occurs: (i) ordering error where an incorrect item is shipped in accordance with purchase order, (ii) an order is cancelled while in transit or (iii) delivery is refused by customer.

Span reserves the right to issue credit amounts based on strict adherence to this policy.

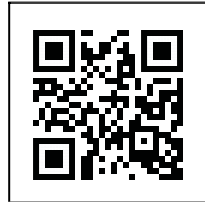

Advena, Ltd.
Tower Business Centre, 2nd
Flr, Tower Street, Swatar, BKR
4013, Malta

Australian Sponsor:
KD&A Pty Ltd.
286 Flinders Street
Adelaide, South Australia, 5000
(ACN 114 941 338)

Span-America Medical Systems, Inc.
Greenville, SC 29606
(800) 888-6752

ECO # 2604

P16792 r1

www.spanamerica.com | © 2021 Span-America